

TYPE 3 - WITH BUSH, WITHOUT ROLLER

Chain No.	Pitch (P)	Width between Inner Plates (W) (Min)	Roller Dia (D) (Max)	Plate Height (H) (Max)	Pin Inner Diameter (d1) (Min)	Pin outer Diameter (d2)	Pin Length (A) (Max)	Avg. Weight Per Metre (Kg)	Strength (KN) Min	End Condition
B 083 01 HP 01	12.70	7.75	8.51	11.80	4.50	6.28	17.20	0.58	9.32	E
B 101 01 HP 01	15.875	9.65	10.16	14.70	5.18	7.02	19.60	0.73	12.75	E
B 102 01 HP 01	15.875	9.53	10.16	14.70	5.18	7.02	20.50	0.85	18.14	E
B 120 01 HP 01	19.05	11.68	12.07	16.10	5.85	8.09	22.70	1.10	12.75	E

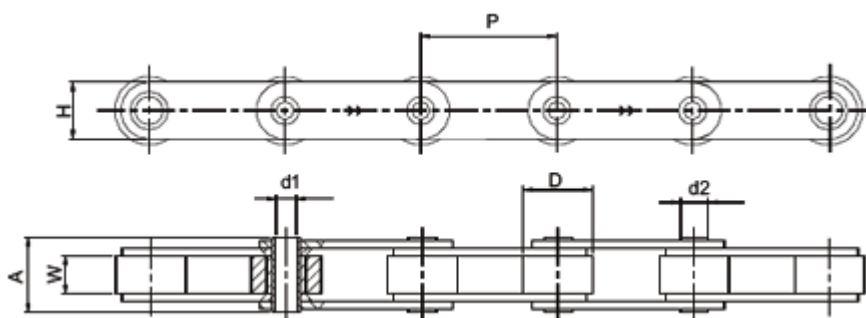

TYPE 4 - DOUBLE PITCH HOLLOW PIN CHAINS

Small Roller Chains

Chain No.	Pitch (P)	Width between Inner Plates (W) (Min)	Roller Dia (D) (Max)	Plate Height (H) (Max)	Pin Inner Diameter (d1) (Min)	Pin outer Diameter (d2)	Pin Length (A) (Max)	Avg. Weight Per Metre (Kg)	Strength (KN) Min	End Condition
A 102 01 HP 01	31.75	9.40	10.16	14.58	5.16	7.02	20.50	0.88	16.00	E
A 121 01 HP 01	38.10	12.57	11.91	18.06	5.99	8.38	25.50	1.08	22.70	E